

AMEND		REVISION REASON	
MARK	DATE	REVISION ITEM	
△	18/02/01	CABLE SPEC	Change cable specifications and add drawings

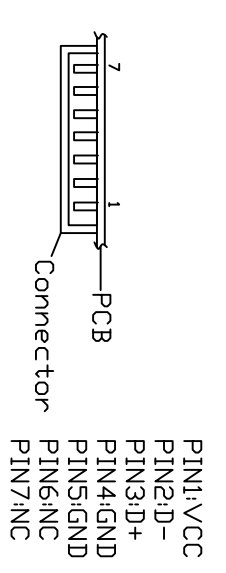
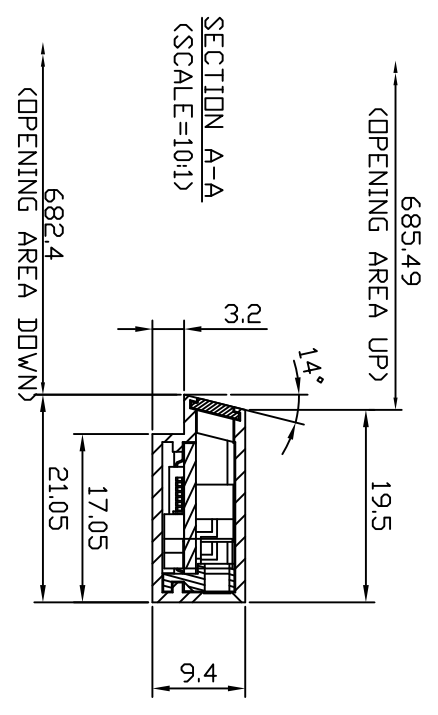
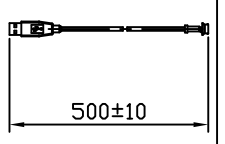
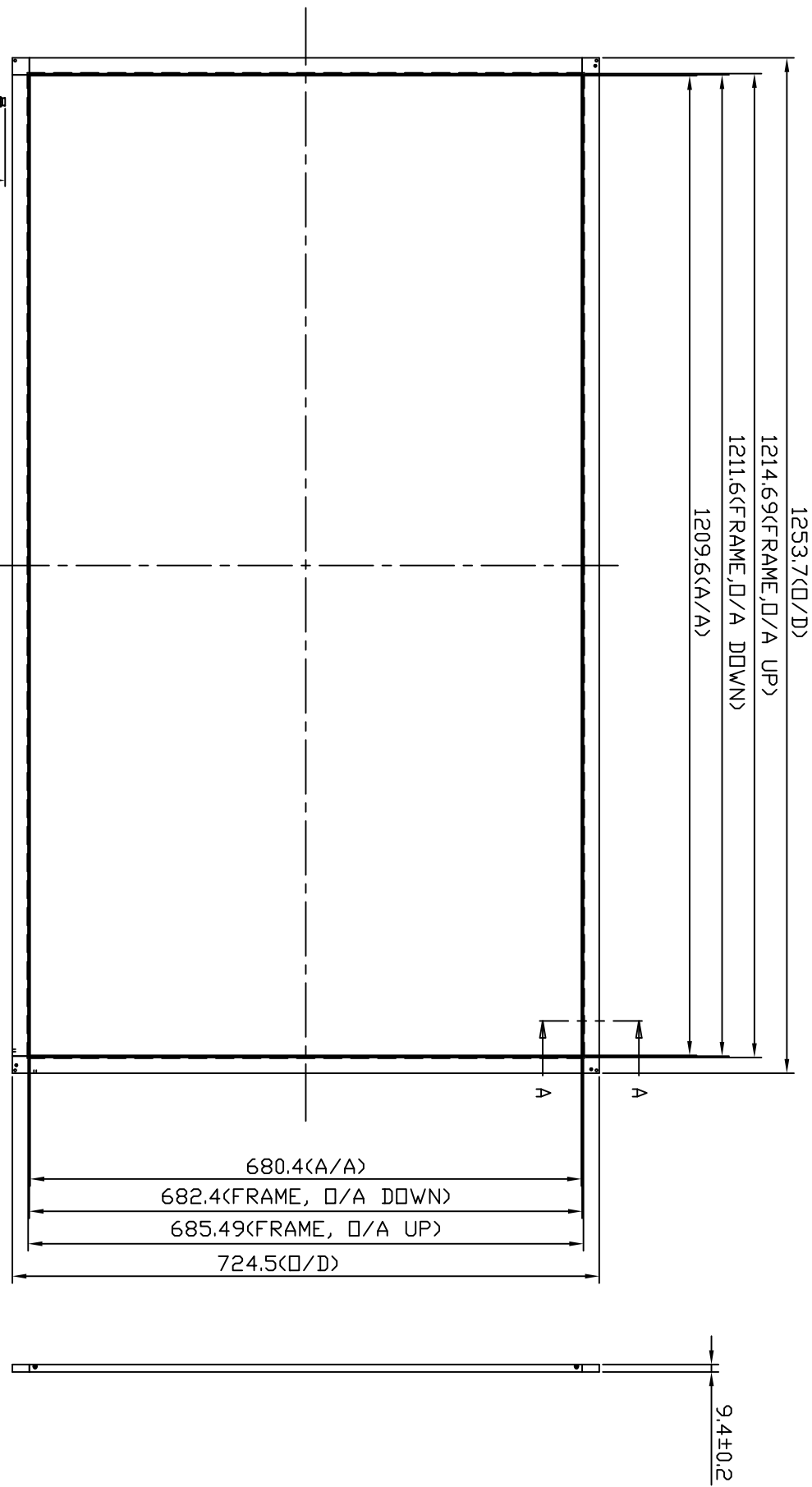

NO	PART NO.	PART NAME	Q'TY	MATERIAL	COLOR/FINISH
		TIKTouch-TXXX			

MODEL NO.	SCALE	UNIT	RMK'S
PART NO. XXX-XXX	1:1	mm	
PART NAME T550		A3	
MATERIAL		SIZE	
YY/MM/DD 18/02/27		SHEET	1/1
DWG NO.		REV. NO.	
DWG NAME		CHK'D	
DRAWN		APP'D	

TOLERANCES	ANGLES ±0.5°
>200mm	±2.00mm
160mm~200mm	±1.20mm
120mm~160mm	±0.80mm
80mm~120mm	±0.50mm
40mm~80mm	±0.30mm
120mm~40mm	±0.20mm
30mm~120mm	±0.15mm
530mm	±0.15mm

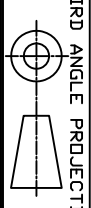

T1 KOREA CO., LTD.